

# INSTRUCTION MANUAL



GB

## USER TERMINAL: EVOLUTION



<b>U I A</b> General characteristics	2	<b>U I A</b> "LAN" - local network	19
<b>U I A</b> User interface	2	<b>U I A</b> Practical procedure for setting up a lan of units	20
<b>U I A</b> Main screen	3	Interconnection between the units by shielded cable	20
<b>U I A</b> Flow charts for accessing the screens	6	Setting the addresses of the units (from 0 to 10) and the user terminals (from 11 to 20)	21
<b>U I A</b> Default values configuration	11	Configuring the software for the recognition and management of the units	22
<b>U I A</b> Ambient temperature control diagrams	12	Special functions of the LAN network	22
<b>U I A</b> Ambient temperature control diagrams	13	<b>U I A</b> Serial boards and supervisory system	26
<b>U I A</b> Ambient humidity control diagram	14	<b>U I A</b> Troubleshooting	29
<b>U I A</b> Dual fluid unit	14		
Freecooling unit	15		
Emergency function	16		
"Economy" function	16		
EC inverter fan speed automatic regulation	17		

The following symbols are used in this publication and inside the unit:



**User**



**Important**



**Installer**



**Prohibition**



**Assistance**

In some parts of this manual, the following symbols are used:



**WARNING** = for actions that require special care and suitable preparation



**PROHIBITED** = for actions that absolutely MUST NOT be performed

**Specialist personnel**  
(electrician)

Person with in-depth knowledge and experience such as to be able to recognise risks and avoid dangers that may derive from electricity (IEV 826-09-01).

The EVOLUTION controller allows independent control of all the unit operating parameters.

The controller is made up of:

- A microprocessor control board housed inside the electrical panel
- A user terminal or graphic interfacell. The program that resides on the control board can be used on all types of precision air-conditioning units, specifically:
  - direct expansion units, air- or water-cooled
  - water chiller units
  - direct expansion units with energy saving function;
  - dual cooling units.

The main functions of the program are

- management of the temperature and humidity in civil or technological environments;
- management of 1 or 2 scroll compressors;
- management of between 1 and 3 electric heating stages for heating and post-heating;
- management of modulating valves for cooling using cold water and heating using hot water;
- management of the evaporator fan speed, when featured;
- management of an external or built-in immersed electrode humidifier;
- outlet temperature control;
- management of alarms and maintenance warnings;
- logging of up to 100 alarm events;
- device safety times;
- unit on/off from user terminal, remote contact, supervisory system and according to time bands;
- local network (LAN) connection for managing backup units;
- connection to local supervision networks and BMS (LonWorks, BACnet, Modbus.....).

The terminal can be used to display and modify (on entering a password) the following data, at any time:

- values read by the probes and the corresponding calibration;
- active alarms, alarm log, configuration of the alarm digital outputs;
- configuration of the local network (LAN);
- parameter settings for serial communication with the supervisory system;
- configuration parameters and fundamental control parameters;
- operating hours and number of starts of the controlled devices;
- clock and time band settings
- selection between the different languages available.

Using the local network connection, the program can manage the following additional functions:

- automatic rotation, by time or event, between a maximum of 10 units;
- management of the average temperature and humidity readings from a maximum of 10 units;
- use of just one terminal to control a maximum of 10 units;

In order to protect the program default settings, the software features two levels of password, USER for the main user settings, and FACTORY for the authorised technicians, used to modify and reset all the software parameters.

## USER INTERFACE

# U I A

The user interface is made up of:

- 11x15 pixel backlit LCD;
- 6 backlit buttons for scrolling and modifying the parameters.

The microprocessor board is connected to the user interface using a 4-pin telephone cable with RJ11 jack.

### Caratteristiche del terminale

Power supply	from the power board through telephone cable or from external source 18 to 30Vdc through TCONN6J000
Power input	PGD1: 1.2W;
Operating conditions	-20T60 °C, <90% rH
Storage conditions	-30T70 °C, <90% rH
Index of protection	IP65 with panel mounting, IP40 with wall mounting
Resolution	132X64
Back-lighting	green LED
Buzzer	NOT AVAILABLE
Row number	8
pLAN	default

#### ALARM button functions:

- reset the active alarms
- flashes red in the event of active alarms
- to stop buzzer durino an alarm

#### PRG button:

access the configuration menu.

#### ESC button:

exit the screens

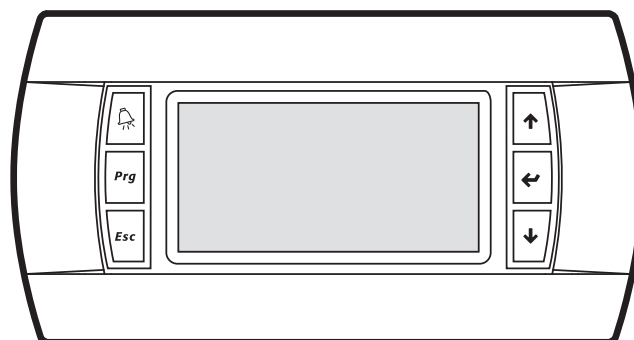

#### UP button functions:

- scroll and/or change screen
- modify the values
- to move inside the manu

#### Enter button functions:

- confirm the modifications
- access the areas for modification

#### DOWN button functions:

- scroll and/or change screen
- modify the values
- scroll inside the menus

The following figure shows the layout of the main screen.

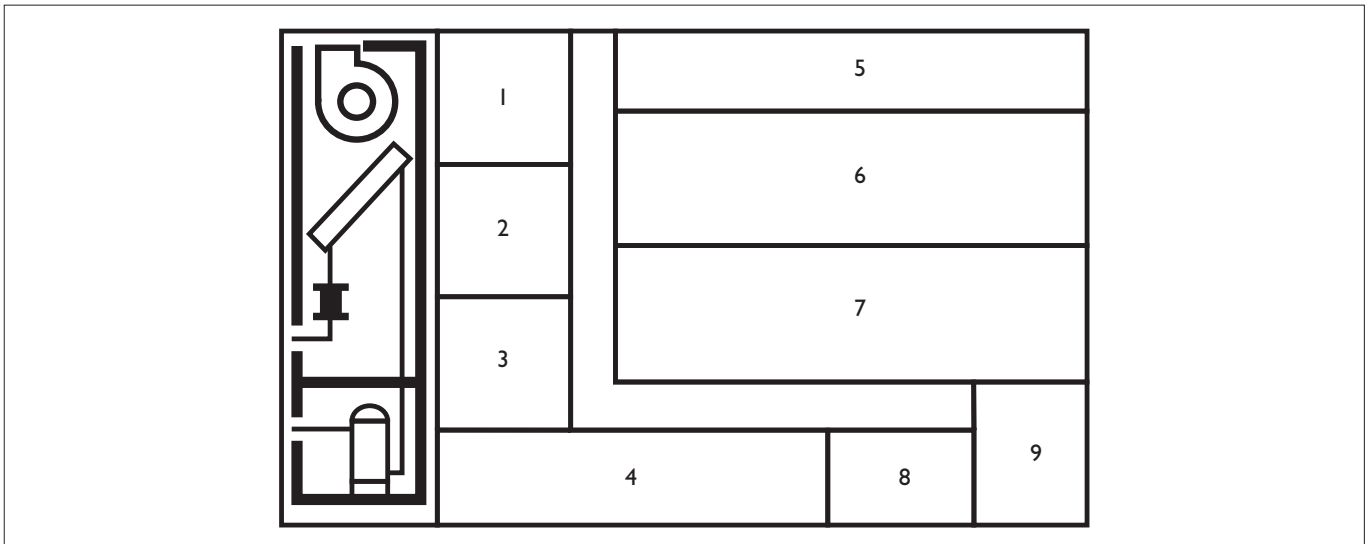

**Area 1 - GENERAL STATUS OF THE UNIT.**

















	Unit off
	Unit functioning in NORMAL mode
	Unit functioning in CONSTANT AIR FLOW mode
	Unit functioning in CONSTANT AIR FLOW (Max Air Flow admitted) mode
	Unit functioning in CONSTANT ΔP mode
	Unit functioning in CONSTANT ΔP (Max Air Flow admitted) mode



















**Area 2 - DETAILED INDICATION OF THE UNIT STATUS.**

	presence of an active alarm
	maintenance signal
	manual controls active
	unit on/off from terminal
	unit on/off from remote contact
	unit on/off from supervisory system
	unit on due to emergency via the network (LAN)
	unit in standby (unit off due to the rotation of the unit in standby)
	unit in EMERGENCY mod
	unit on due to temperature/humidity limits exceeded
	unit on/off due to time programming
	unit ON for High Humidity Limit overcoming (flashing)
	unit ON for Low Humidity Limit overcoming (flashing)

### Area 3 - ALLARM LIST

This area displays an icon that, in the event of alarms or maintenance signals, respectively indicates the type of alarm and the device that requires maintenance.

	EEPROM fault
	LAN disconnected
	Water leak
	High pressure in circuit 1
	High pressure in circuit 2
	High pressure
	Low pressure in circuit 1
	Low pressure in circuit 2
	Low pressure
	High ambient temperature
	Low ambient temperature
	High ambient humidity
	Low ambient humidity
	Air flow alarm
	Incorrect phase sequence
	Filters blocked
	Fire/smoke detected

	Wrong password (5 attempts)
	Electric heater overheat
	High water temperature
	High humidifier current
	High humidifier current
	Low humidifier current
	No water in humidifier
	Room temperature probe fault
	Room humidity probe fault
	Outlet air temperature probe fault
	Outside air temperature probe fault
	Cold water temperature probe fault
	Hot water temperature probe fault
	Fire/Smoke or water alarm
	Electronic valve fault
	Electronic valve fault in circuit 1
	Electronic valve fault in circuit 2
	Air pressure trasducer fault
	Expansion I/O board fault

### EVENT OF ALARM

In case of Alarm event:

- Acoustic signalling is activated (buzzer);
- Red led under the alarm buttons activated;
- Green leds on main screen are activated
- AREA 2 on main screen is showing the alarm icon;
- AREA 3 on main screen visualized an icon who represent the kind of active alarm .

With a single press on the alarm button the acoustic signalling is de-activated.

### RESET OF ALARM STATUS

To make the ALARM RESET, we split the alarms in 3 different kind:

- Alarms with only Automatic Reset: in this category we found only the alarm "LAN DISCONNECTED".
- Alarms with Automatic/Manual Reset (based on the customer's settings on screen I3); in this category we found:
  - Ambient Temperature Limits overcoming
  - Ambient Humidity Limits overcoming
  - Chilled Water too high
  - Water Flow missing
  - Low Pressure alarm
  - Humidifier alarm
  - Air filter alarm

By default alla bove are setted with AUTOMATIC RESET.

- Alarms with only Manual Reset:

After removing the alarm cause, it's required to push alarm button for few seconds to remove completely the alarm signalling and will disappear any Alarm icon from AREA 2 and AREA 3.

With "Wrong Password Alarm", the RESET is only manual after the right input of the correct password.

## ALARM LIMITS

With User Password (screens “I”): it's possible to modify the alarms limits setted like, Ambient Temperature Limits overcoming, Ambient Humidity Limits overcoming, Chilled water too high( 2 limits: 1 for standard functioning, 2 for dehumidification functioning) anyway based on unit configuration.

## ALARMS OUTPUTS















With User Password (screens “I”): it is possible to configure the alarms output available on the main board. Based on unit configuration we can have 1 Alarm output (marked A) or 2 Alarm outputs (marked A & B).

We can also set:

- Status of Alarm Contacts (normally Open or Closed in OFF position: in this second case we can also raise the “power missing alarm”);
- Address the desire alarm in contact A or B , depending on customer choice.

## Area 4

This area displays icons corresponding to the devices currently installed on the unit.

	compressor 1 active
	compressor 2 active
	compressors 1 and 2 active
	first electric heater stage active
	second electric heater stage active
	third heater stages active
	Dehumidification active
	Humidification active
	Cold water valve open
	Hot water valve open
	Hot gas active
	Compressor 1 + cold water valve open
	Compressor 2 + cold water valve open
	Compressor 1 & 2 + cold water valve ope
	Compressor active + cold water valve open

## Area 5

This area displays the time and date, if the clock board is fitted.

## Area 6

This area displays the room temperature currently read by the probe on the unit (even if the control is enabled based on the average of the values read by the units connected in the LAN).

## Area 7



This area displays the relative humidity currently read by the probe on the unit (even if the control is enabled based on the average of the values read by the units connected in the LAN).

## Area 8

This area indicates the LAN address of the unit, if connected to other units.

## Area 9

This area indicates the unit on/off mode from the user terminal.

	press ENTER to switch the unit off
	press ENTER to switch the unit on

MAIN LOOP SCREENS

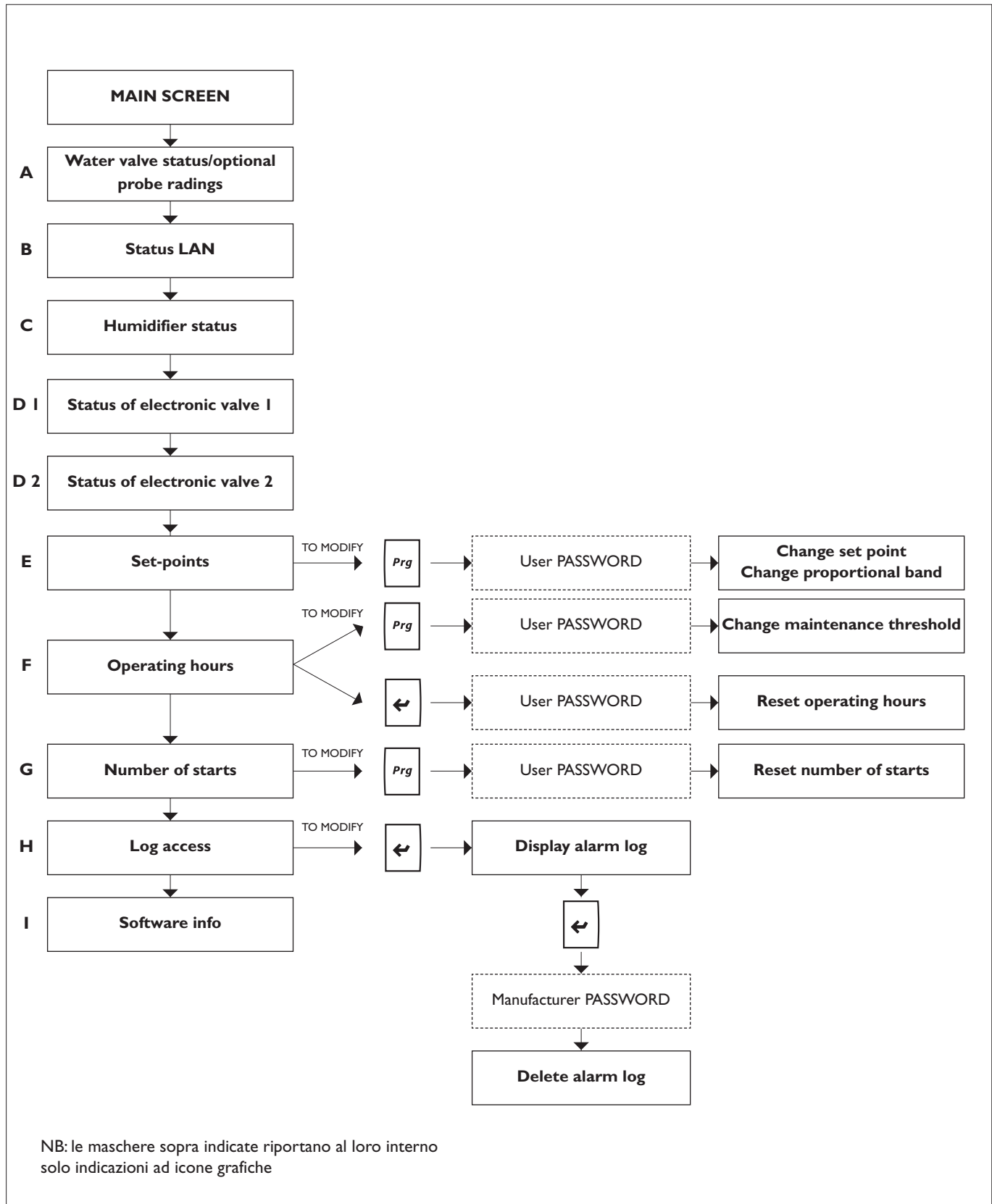

## STATUS SCREENS

Starting from the main screen, pressing the UP/DOWN buttons accesses the other status screens, which are, in order:

**A WATER VALVE STATUS/OPTIONAL PROBE READINGS:** screen displaying the temperature values read by the optional probes (outlet air temperature probe, chilled water temperature probe, hot water temperature probe, outside air temperature probe) and the percentage of opening of the cold and hot water modulating valves;

**B LAN STATUS:** screen displaying the status of all the units connected in the LAN;

**C HUMIDIFIER STATUS:** screen displaying the status of the humidifier, with all the technical operating values;

**D STATUS OF ELECTRONIC VALVE:** Screens displaying the data corresponding to the operation of the electronic thermostatic valve in circuit 1 and, for two-circuit units, corresponding to the operation of the electronic thermostatic valve in circuit 2

**E SET POINTS:** screen displaying the active control set point; from this screen, pressing PRG and entering the first level password, accesses a further screen used to modify the set point and proportional band corresponding to each type of active control (cooling, heating, dehumidification, humidification);

**F OPERATING HOURS:** screen displaying the total operating hours of the devices installed on the unit; from this screen, following the instructions shown on the display and after entering the first level password, the operating hours for each device can be reset (set to zero), or the thresholds for activating the maintenance signal can be changed;

**G NUMBER OF STARTS:** screen displaying the total number of activations for the devices installed on the unit; from this screen, following the instructions shown on the display and after entering the first level password, the number of starts for each device can be reset

**H LOG ACCESS:** screen for accessing the display of the alarm log;

**I SOFTWARE INFO:** screen displaying information on the software installed.

**A** Water valve status/optional probe readings

**B** Status LAN

**C** Humidifier status

**D 1** Status of electronic valve 1

**D 2** Status of electronic valve 2

**E** Set-points

**F** Operating hours

**G** Number of starts

**H** Log access

**I** Software info

SETTING PARAMETERS SCREENS

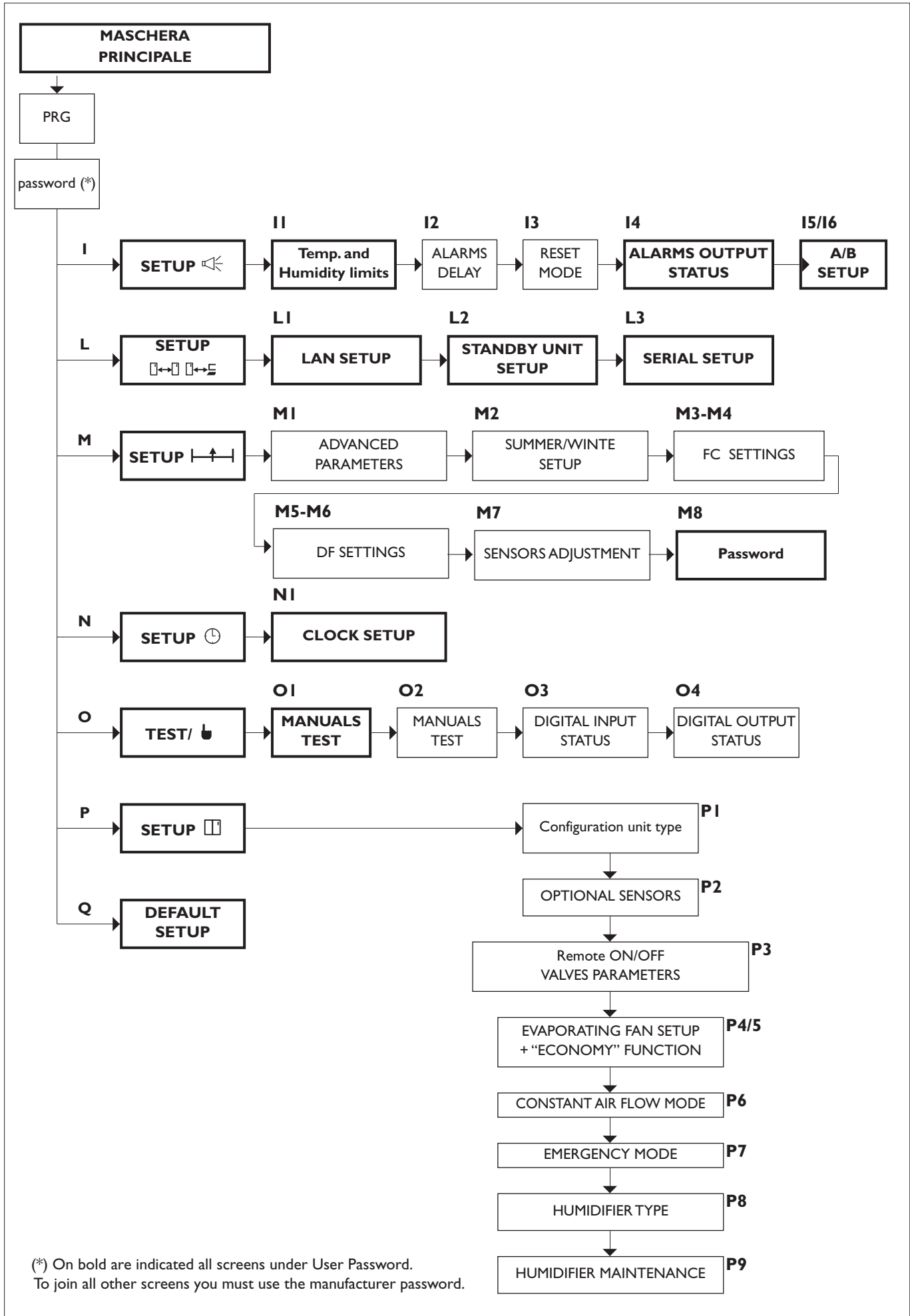

## MSCREENS FOR SETTING THE PARAMETERS

Starting from the main screen, pressing the PRG button and entering the correct password accesses a menu used to set all the other parameters that are not available on the status screens, as described in the previous paragraph.

Two passwords can be entered:

- **User password:** accesses the user parameters, that is, the parameters considered as being useful and easy to understand for the user;
- **Manufacturer password:** accesses all the parameters, that is, both the user parameters and the manufacturer parameters.

The complete menu items are as follows:

### I SETUP (alarms setting):

this menu is used to set the thresholds for the limit alarms (high and low ambient temperature, high and low ambient relative humidity, high water temperature), the delays for some alarms, the type of reset (automatic or manual) for some alarms, and the addresses of the alarm digital outputs available on the controller;

### L SETUP (LAN/serial/modem):

(user password)

this menu is used to configure the local network (LAN) and set all the corresponding parameters, as well as the serial communication parameters;

### M SETUP (control settings):

(manufacturer password)

this menu is used to manually control all the devices on the unit, disabling normal automatic control;

### N SETUP (clock setup) :

(user password)

this menu is used to set the current time and date, if the clock board is fitted;

### O TEST/ (test/manual control):

(manufacturer password)

settings that involve the configuration of the unit, that is, the devices, probes and sensors on the unit; ; it is also possible to check the status of each single contact ( INPUT & OUTPUT) of the main board;

### P SETUP (unit configuration):

(manufacturer password)

this menu is used to modify some critical parameters that are part of the control algorithm inside the control system;

### Q DEFAULT SETUP:

(manufacturer password)

this menu is used to restore the default parameter values; important: this operation also deletes the alarm log (this can also be deleted on the screen displaying the log, as indicated on the display and after entering the second level password), while it does not cancel the basic configuration of the unit.

## SCREENS “I”

### Screen “I1”

Used to modify alarms limits for: ambient temperature, ambient humidity & chilled water temperature.

### Screen “I2”

Used to modify the alarms delay and in particular:

- Air flow alarm delay after fans starting
- Ambient temperature & Humidity alarm limits delay
- Air Filters alarm delay
- Low Pressure alarm delay after compressor starting

### Screen “I3”

Used to set kind of RESET: Automatic or Manual (only for alarms where it's allowed by manufacture)

### Screen “I4”

Used to set STATUS of alarms contact

### Screens “I5”, “I6”

Used to address the the alarm contact, type A or B.

## SCREENS “L”

### Screen “L1”

Used to set all parameters of LAN connection like:

- Number of units in LAN
- Temp. and Humidity average value mode activated
- Abilitation of Stand by unit
- Rotation cycle time
- Number of Stand by unit (max 2 in case we have more than 4 units connected)
- Activation of Stand by unit for overcoming limits by Master unit.

### Screen “L2”

Used to modify regulation set-points on Stand by unit, is function has been activated on screen L1

### Screen “L3”

Used to modify all settings related to the serial connections.

## SCREENS “M”

### Screen M1

Used to set advanced parameters for temperature and humidity control like:

- delay at start up after power back from failure
- Integral time
- Abilitation of air delivery sensor (when optino is required) and relative set points.

### Screen M2

Screen active only on chilled water units to activate reverse cycle control, COOLING / HEATING. (Cooling: cold water in the coil; HEATING: hot water in the coil)

### Screens M3/M4

Screen active if the unit is configured as FREECOOLING, used to set the main parameters.

### Screen M5/M6

Screen active if the unit is configured as DUAL FLUID, used to set the main parameters

### Screen M7

Used to adjust the value read by Temp. sensors.

### Screen M8

Used to modify the PASSWORD.

## SCREENS “N”

### Screen N1

Used for clock settings

## SCREENS “O”

### Screen O1 and O2

Used to activate manually the unit and also each single componets installed on it.

### Screen O3 and O4

Used to check all contact available on board

## SCREENS “P”

### Screen P1

Used to set the main importat/foundamental features of each unit

### Screen P2

Used to set eventually optional sensors

### Screen P3

Used to set the Remote ON-OFF via el. Contact and the time costants values for water valves 3 points.

### Screen P4

Used to modify parameters related to Electronic backward curved EC Fans, like:

- Standard speed
- Energy saving speed when uniti s not in regulation.

### Screen P5

Used to modify parameters related to Electronic backward curved EC Fans, when it is related to 3 way chilled water valve. Then this is screen is availavle only for AC\* (chilled water unit).

### Screen P6

Screen used for constant air flow & constant  $\Delta P$  modes parameters setting.

### Screen P7

Used to activate the Emergency Mode: when the dedicated contact on the board activate the Emergency mode, only the components reported inside this screen remain in ON, in order to save energy.

### Screen P8

Used to modify and set Humidifier parameters.

### Screen P9

Used to temporary disabling the Humidifier in order to provide its maintenance or replacement.

	U.M.	DEFAULT	MIN	MAX
<b>Set points and differential band</b>				
Cooling set point	°C	24	18	32
Cooling proportional band	°C	1.5	0.5	9.9
Heating set point	°C	24	12	30
Heating proportional band	°C	1.5	0.5	9.9
Dehumidification set point	%	55	45	90
Dehumidification proportional band	%	5	3	15
Humidification set point	%	45	10	55
Humidification proportional band	%	5	3	15
<b>Maintenance operating hour threshold</b>				
Fan	h	00000	00000	32767
Compressor 1	h	00000	00000	32767
Compressor 2	h	00000	00000	32767
Heaters 1	h	00000	00000	32767
Heaters 2	h	00000	00000	32767
Humidifier	h	00000	00000	32767
<b>Alarm parameters</b>				
High ambient temperature threshold	°C	32	20	50
Low ambient temperature threshold	°C	10	0	30
High ambient humidity threshold	%	80	30	99
Low ambient humidity threshold	%	30	0	70
High water temperature threshold	°C	15	5	50
High water temperature threshold in dehumidification	°C	7	0	30
Flow alarm delay after unit start-up	s	15	15	999
Alarm delays when exceeding temperature and humidity limits	s	60	0	999
Blocked filter alarm delay	s	8	2	999
Low pressure alarm delay after compressor start	s	180	2	999
Reset temperature limit alarm		Auto	MAN	Auto
Reset humidity limit alarm		Auto	MAN	Auto
Reset high water temperature alarm		Auto	MAN	Auto
Reset low pressure alarm		Auto	MAN	Auto
Reset humidifier Alarm		Auto	MAN	Auto
Reset water flow alarm		Auto	MAN	Auto
Select alarm output		A		
<b>LAN parameters</b>				
High temperature threshold to switch the unit on in standby	°C	30	20	50
Low temperature threshold to switch the unit on in standby	°C	18	0	30
High humidity threshold to switch the unit on in standby	%	75	55	90
Low humidity threshold to switch the unit on in standby	%	35	10	45
<b>Serial parameters</b>				
Serial address		I		
Serial baud rate	baud	1200		
Protocol		Standard		
<b>Advanced control parameters</b>				
Unit start delay	s	0	0	999
Control start delay after unit start-up	s	60	20	999
Integration time	s	900	0	999
Enable minimum outlet air temperature limit		Y		
Minimum outlet temperature limit set point	°C	12	0	25
Enable dehumidification function		Y		
Hot water activation set point	°C	40	20	99.9

1. Direct expansion version: AXO-AXU, AWO-AWU

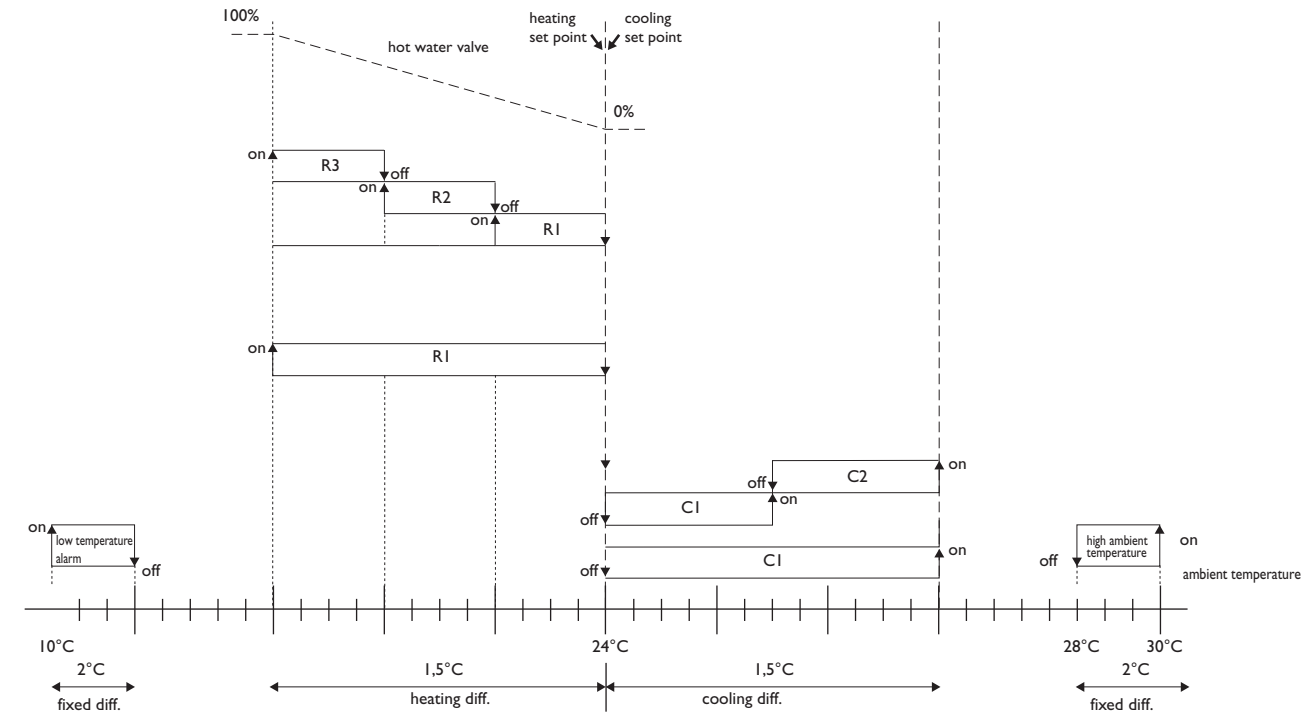

2. Chilled Water & Dual Coil version: ACO-ACU, ABO-ABU

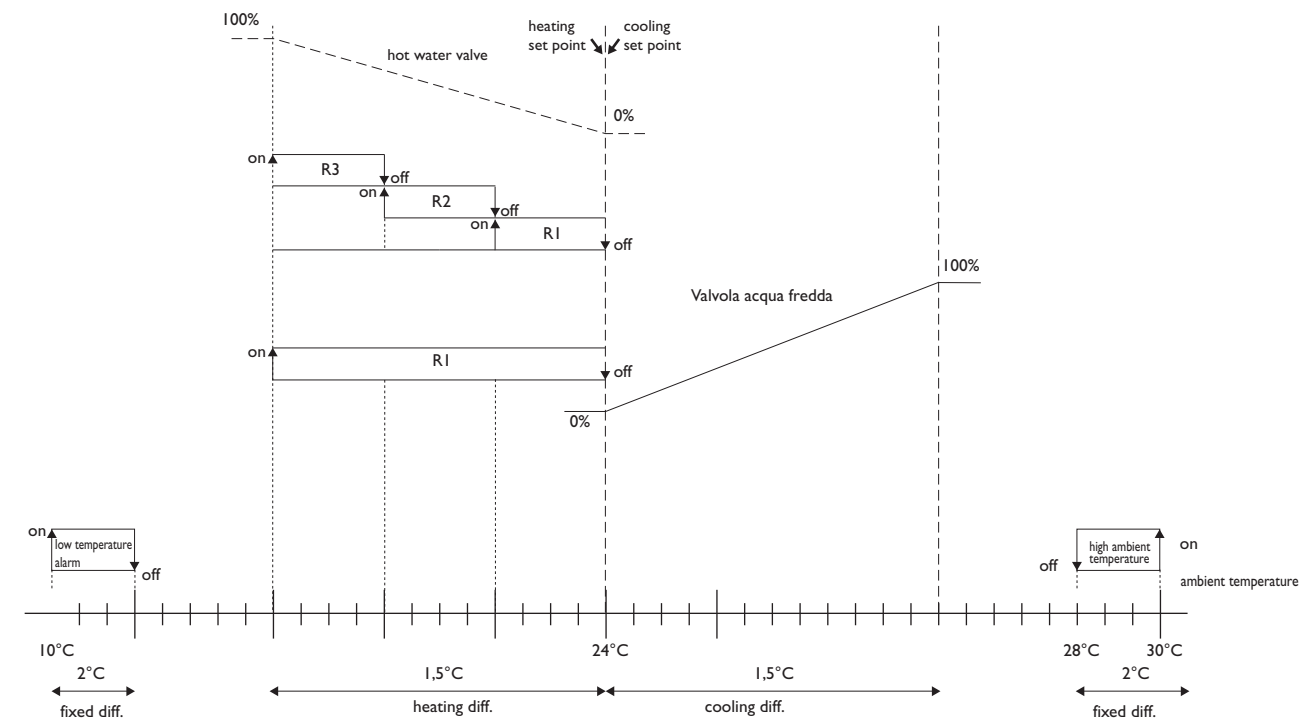

3. Dual Fluid version: ATO-ATU; ADO-ADU

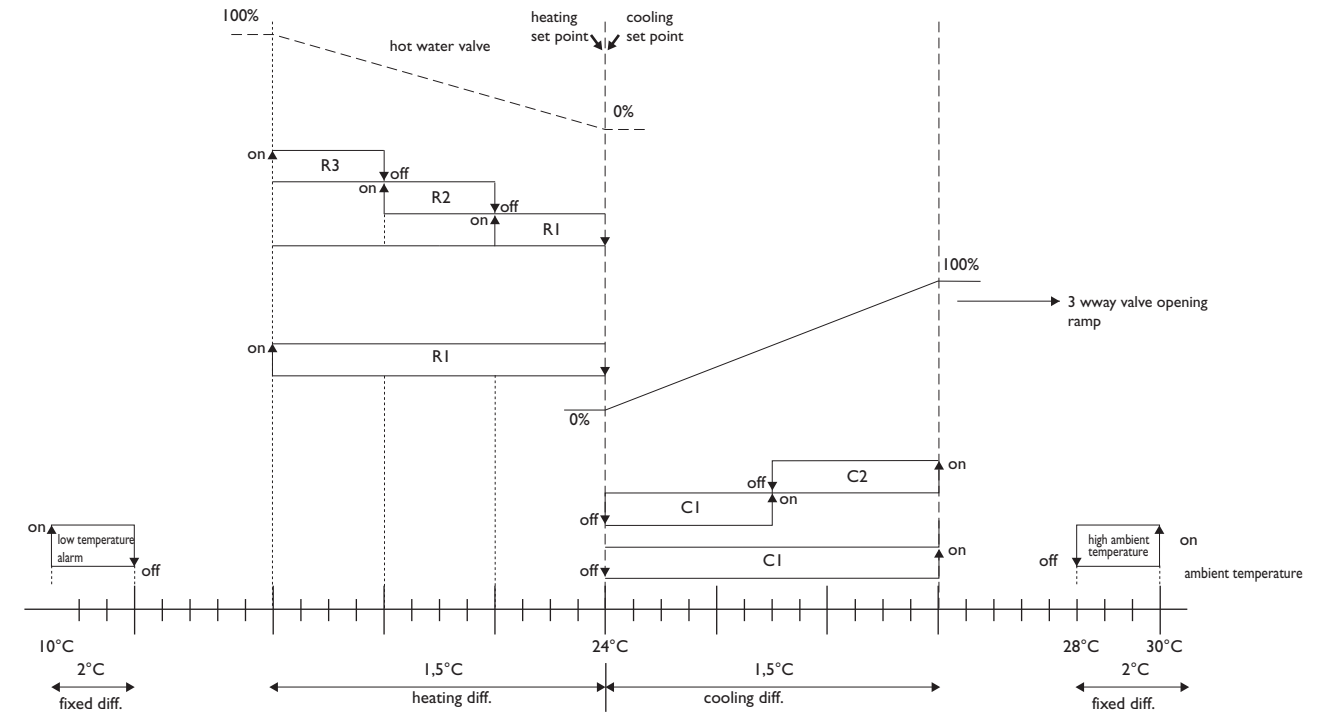

4. Free Cooling version: AFO-AFU

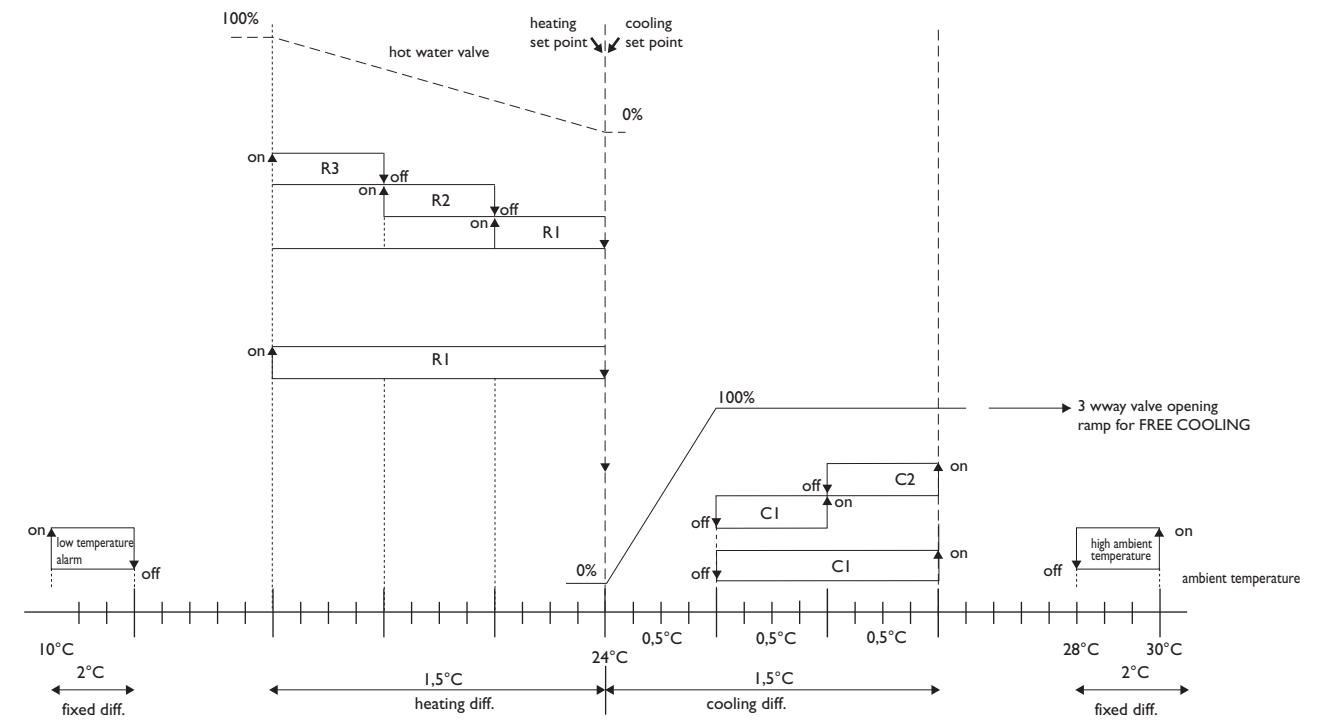

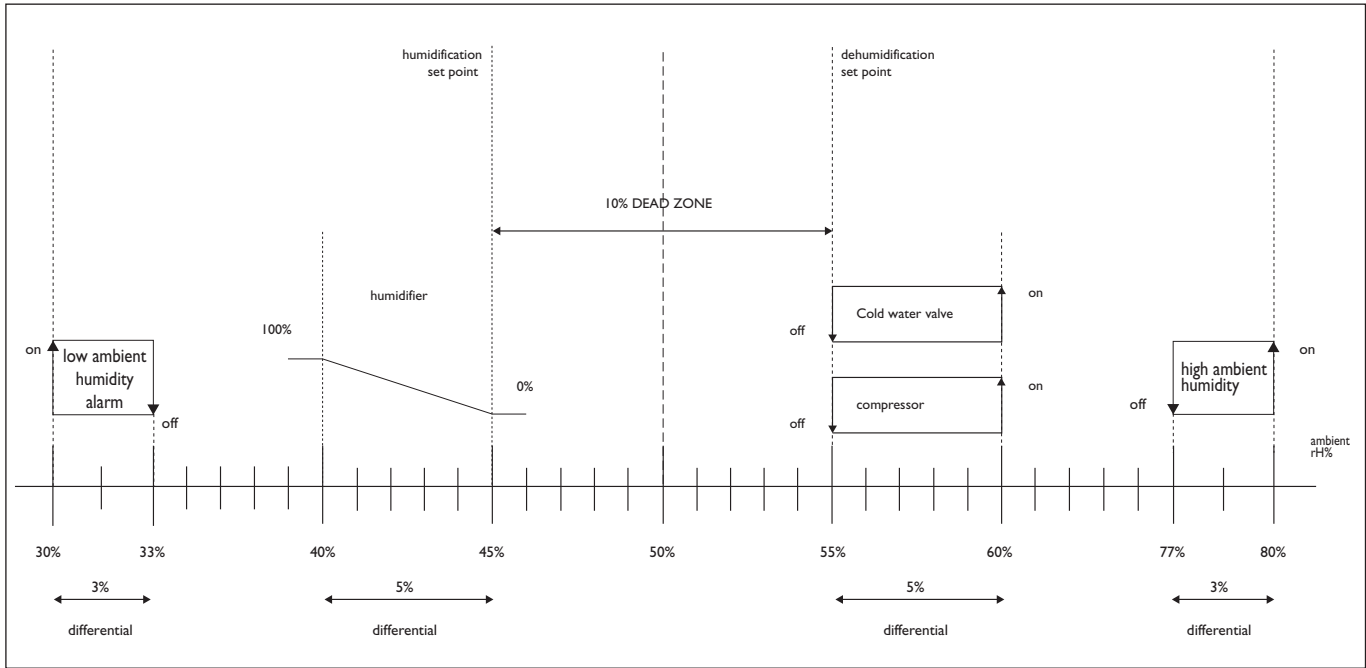

DUAL FLUID UNIT - ATO-ATU; ADO - ADU

INTRODUCTION

The changeover between direct expansion operation and chilled water operation (and vice-versa) can be performed in one (and only one) of the following three ways:

- changeover based on the temperature of the chilled water (default);
- changeover controlled by digital input;
- changeover controlled by supervisor (via serial).

If direct expansion operation is disabled, then all changeover management modes are ignored and the unit always works with chilled water. The opposite is true when chilled water operation is disabled. Obviously, both operating modes cannot be disabled together.

The unit changeover mode and the disabling of one type of operation (direct expansion or chilled water) can be set on screen M5 shown below, with the default settings also indicated.

DUAL COOLING SETTINGS:

Disable CW Mode: N  
 Disable EX Mode: N

EXCHANGE MODE ENABLE:

Standard (Wat.Temp.) Y  
 Remote Contact: N  
 Serial Command: N

CHANGEOVER ACCORDING TO THE WATER TEMPERATURE

The main changeover mode involves constant monitoring of the water temperature: if this satisfies the set conditions, then chilled water operation starts automatically, otherwise the unit works in direct expansion mode.

The water temperature condition is expressed by the step shown in the following figure.

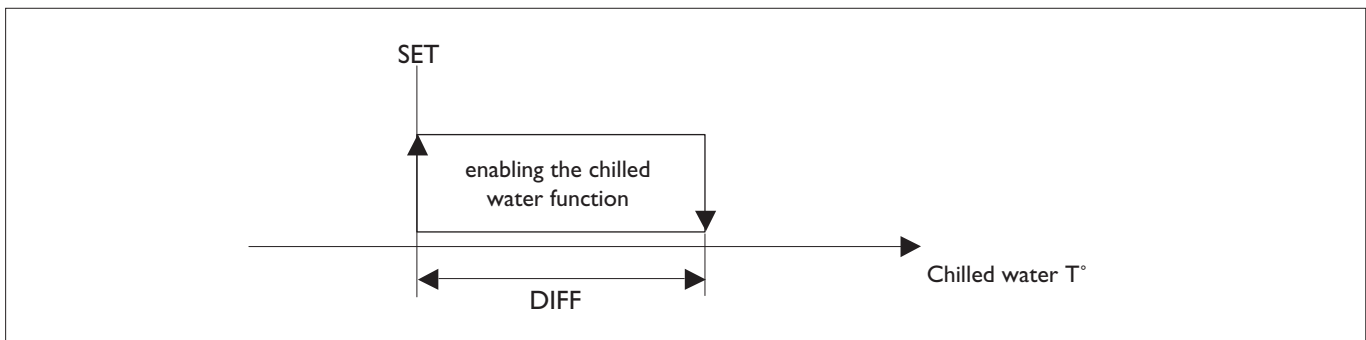

Both the SET and the differential can be set on the user terminal as shown in screen **M6** below, with the default settings also indicated (SET = 7°C and DIFF = 5 °C).

<b>STANDARD EXCHANGE MODE</b>	
<b>CW-MODE START SET:</b>	
Water temp.	< °C 07.0
<b>CW-MODE STOP SET:</b>	
Start Set	+ °C 5.0

tion described for the step above, at least 12 minutes must elapse since the last changeover before the unit can start chilled water operation again.

The changeover to direct expansion operation is also performed when, during chilled water operation, one of the two following alarms is activated:

- high ambient temperature alarm;
- chilled water temperature probe fault alarm.

## FREECOOLING UNIT - AFO - AFU

The microprocessor controller on the air-conditioner monitors both the outside air temperature and the difference between the **water IN temperature (water in the closed circuit) and the ambient temperature (in the room)**; the objective is to control the ambient temperature based on the set point and at the same time maximise the freecooling effect, that is, energy saving.

The microprocessor measures the **water IN temperature (water in the closed circuit)** using an NTC temperature probe, and if this is less than the ambient temperature (**Ambient temperature – Water IN temperature > 7°C**), the Freecooling function is activated, opening the 3-way valve to supply the water coil.

When the difference between the ambient temperature and the water IN temperature falls back below 5°C (**Ambient temperature – Water IN temperature < 5°C**) the Freecooling function is disabled and the unit operates in normal direct expansion mode. In this case, the 3-way valve will be completely closed and the flow of the water will be entirely deviated to the plate exchangers inside the unit for the condensing phase.

All the parameters relating to the management of the Freecooling function are shown on screen **M3** below, included in the software.

<b>FREE-COOLING</b>	
<b>ROOM T.-WATERT.:</b>	
<b>FC start set:</b>	°C 07.0
<b>Differential:</b>	2.0
<b>RAD-COOLER CONTROL:</b>	Y

The microprocessor can, when required, also manage the outside rad-cooler so as to create the conditions for the activation of the Freecooling function.

When the difference between **the ambient temperature (in the room) and the outside air temperature is >8°C** the microprocessor signals (via a contact on the electrical panel) the maximum heat exchange requirement to the outside rad-cooler (meaning that the set point for the outside rad-cooler switches from “NORMAL” to “WINTER”)

When the difference between **the ambient temperature (in the room) and the outside air temperature is < 5°C** the microprocessor controls the outside rad-cooler to optimise operation in direct expansion mode (the rad-cooler operates with the “NORMAL” set point).

All the parameters relating to the management of the outside rad-cooler function are shown on screen **M4** below, included in the software.

<b>RAD-COOLER CONTROL</b>	
<b>CONTROL TYPE:</b>	Contact/Modul
<b>WATER TEMP.SET:</b>	
<b>Normal Set:</b>	°C 35.0 (+Δ6°C)
<b>Winter Set:</b>	°C 6.0 (+Δ6°C)
<b>CHANGE WATER TEMP.SET:</b>	
<b>Room T. – Outdoor T.</b>	
<b>Set:</b>	°C 08.0 Diff.: 2.0

## EMERGENCY FUNCTION

The EMERGENCY (available only on dx dual circuit units of following series AX, AW, AD, AT, AF or on AB) function has been introduced to allowed customer to enable/disable operating devices on the unit, through a dedicated contact. Such functions has been implemented to satisfy all cases where the main power supply can be replaced (in case of black-out) from a UPS or DIESEL power source.

In such cases could be interesting to signal to the Evolution controller the EMERGENCY status in order to disable operative devices that absorb a very high power abs. (expecially heaters, humidifier, compressors).

On **P7** configuration screen it is possible to:

- set the EMERGENCY function
- set the contact status (on input I3)
- to enable/disable operating devices on the unit

### EMERGENCY MODE

<b>Mode Enable:</b>	Y
<b>Norm. Input Status:</b>	
<b>Fan:</b>	Enabled
<b>Compressor:</b>	Disabled
<b>El.Heaters:</b>	Enabled
<b>Humidifier:</b>	Enabled

In case the FANS disabling has been setted, also all others devices will be switched off automatically in the Emergency Mode (also if they apper enable on display).

## "ECONOMY" FUNCTION

### DX UNITS

The ECONOMY function consists on EC Inverter fans speed reduction (down to a presetted value) when no other operating devices on the unit are active (exe: heaters, humidifier, compressors).

The aim is to get maximum ENERGY SAVING from the fans that can be extrremely high if the thermal heat load is dealt with a heterogeneous way.

Such function has to be enabled from **P4** configuration screen

### EVAPORATING FAN SETUP (ONLY WITH EC FAN)

**Regular Speed:** % 070

### ECONOMY MODE

**Economy Enable:** Y  
**Economy Speed:** % 50

### CW UNITS

The ECONOMY function consists on EC Inverter fan speed modulation in relation to the 3way cooling valve opening % as reported on the following schema.

The aim is to get maximum ENERGY SAVING from the fans, that can be extrremely high if the thermal heat load is dealt with a heterogeneous way.

Such function has to be enabled from **P5** configuration screen

### FAN SPEED MODULATION (ONLY WITH EC FAN)

**Enable:** Y  
**Minimum Speed:** % 40  
**Maximum Speed:** % 070

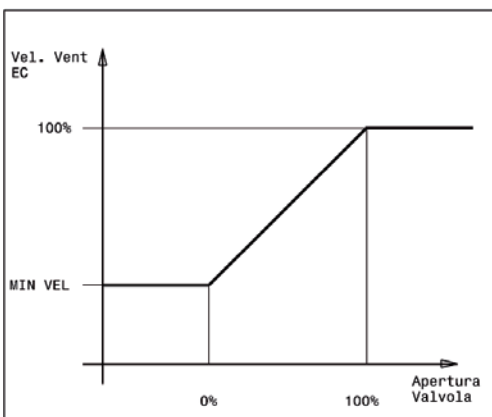

## EC INVERTER FAN SPEED AUTOMATIC REGULATION FOR DX & CW UNITS

This function allows an automatic EC Inverter fan speed regulation. It can be done in 2 ways:

- Regulation having as target a **CONSTANT AIR FLOW**
- Regulation having as target a **CONSTANT  $\Delta P$**  (net after the unit)

Note: it is not possible to use such function on CW units in combination with ECONOMY function.

### REGULATION HAVING AS TARGET A CONSTANT AIR FLOW

The aim is to maintain a constant air flow on the unit and consequently to keep constant and permanent also the unit's performances; this permits to guarantee to customer a right function of the unit.

During the unit lifecycle, the air flow is often influenced by the change of the pressure drops

due to:

- clogged air filters
- variation of ducts extension

When the unit is ordered with the **CONSTANT AIR FLOW** option, it will be provided of a digital pressure trasducer that measures the different pressure value  $\Delta P$  on the fan nozzle as per the following picture:

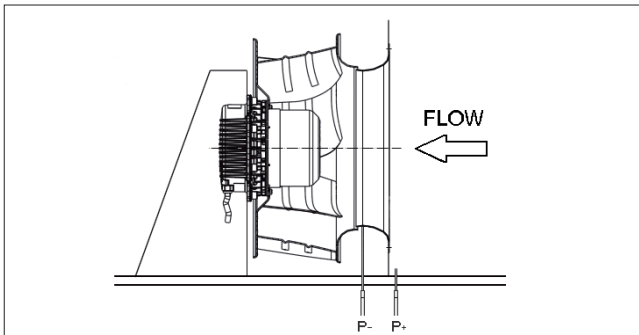

The measured  $\Delta P$  is compared with the value previously setted in factory.

In case there is a difference between the value measured and the value presetted this means that such  $\Delta P$  difference needs a fans speed variation in order to keep the same air flow value and the same unit performances.

Such fan speed adjustment of the rpm is automatically managed from the controller that changes the power input signal to the fans in order to keep the same air flow.

Configuration screen **P6** is the following:

<b>AIR FLOW CONTROL (ONLY WITH EC FAN)</b>	
<b>Control:</b>	<b>Flow</b>
<b>DN EC fan</b>	355
<b>Nr of FAN:</b>	1
<b>Flow target:</b>	02500 m3/h

The regulation & its Llogic are represented on the following graph:

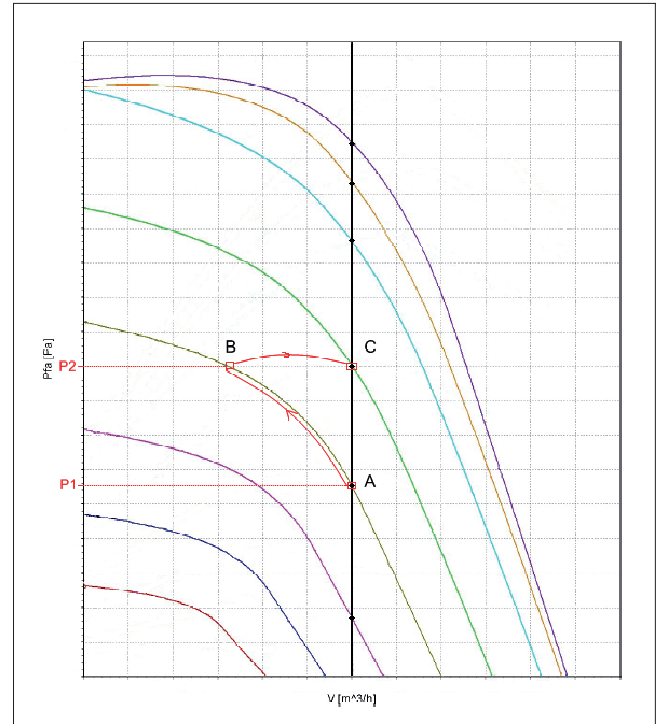

Starting from the nominal value (A) the pressure drop increasing (maybe due to clogged filters) from P1 to P2 causes a working point movement along the curve versus point B and consequently the air flow decreases. Then the controller will raise automatically the fans rpm in order to maintain the same air flow that moves to a new working point C.

## REGULATION HAVING AS TARGET A CONSTANT $\Delta P$

The Aim is to keep constant the  $\Delta P$  value (net after the unit) all along the time on the base of the presetted factory value.

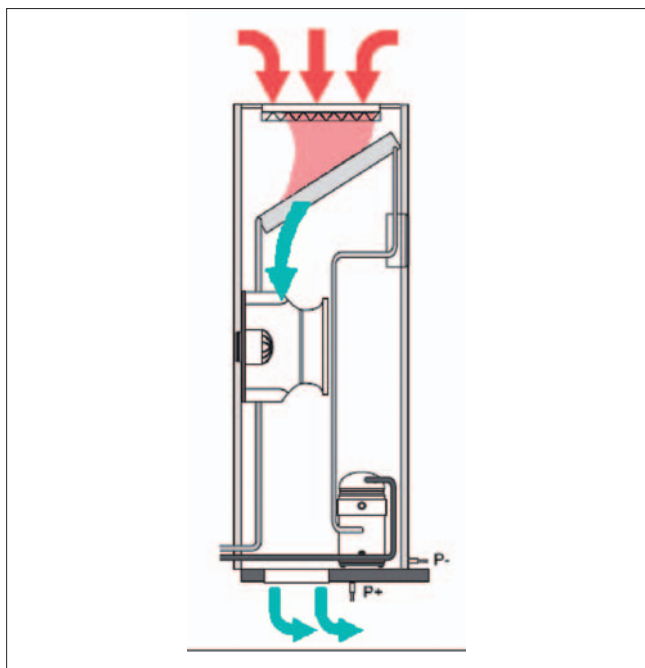

During the unit configuration phase, the  $\Delta P$  value required has to be setted. Additionally, the fans speed is limited to a "min  $\Delta P$  value" in order to get a minimum air flow required from the unit. Also this value has to be setted during the unit configuration.

La maschera **P7** di inserimento dei valori è la seguente:

<b>AIR FLOW CONTROL (ONLY WITH EC FAN)</b>	
<b>Control: Dp</b>	
<b>DP target:</b>	020 Pa
<b>Min vel DP:</b>	040 %

Regulation & its logic is represented on the following graph.

Starting from working point (A) any pressure increasing causes a working point movement along the curve versus point B with a pressure increasing.

The controller then will automatically decrease the fans rpm to maintain same  $\Delta P$  moving to a new working point C.

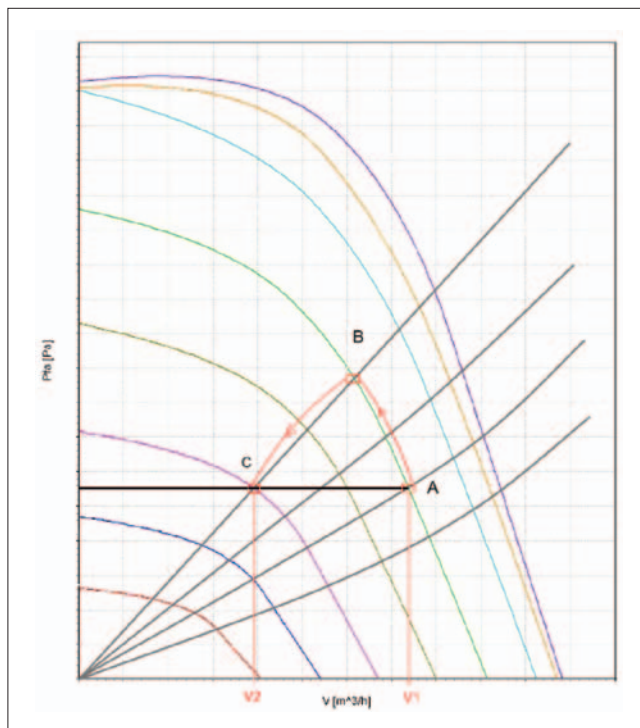

## MAIN FUNCTIONS OF THE LAN

The connection of the units (that is, the PCO boards fitted on each unit) in the pLAN network allows the following functions to be performed:

- balance the operating hours between the air-conditioners by rotation of the standby unit.
- start the standby unit if the other unit shuts down due to a serious alarm or blackout
- start the standby unit to provide for excessive thermal load.
- control up to 10 air-conditioners from just one user terminal (shared user terminal)
- operation of all the air-conditioners based on the average of the temperature and humidity values read by the probes on the air-conditioners that are operating at that moment

1. The local network connection is used to manage the operation of a series of air-conditioners operating inside the same environment,
2. The number of units that can be connected is 10 MAX.
3. The maximum extension of the network connections is **500 metres**.
4. All the units connected in the network must have the **same version of the program** installed in the flash memory on the board.
5. A terminal can be configured as "private" or "shared":
  - a **private terminal** can display the operating status only of the unit it is connected to via telephone cable
  - a **shared terminal** can display the operating status of all the units connected in the network.
6. Each board can "talk" to a maximum of 3 terminals; in common applications, generally no more than two are used: one fitted on the unit and another optional remote terminal.

The priority on the terminal is always the display of the alarms, even if when the alarm is activated the terminal is displaying the parameters from another unit.

7. To be able to communicate over a local network, the units must be configured so as to be able to send the other units the required information for correct operation.

In this regard, the first step involves assigning a progressive number to the different units (1, 2, 3,...10) and then correctly setting the addresses of the various terminals and LAN boards, and making the electrical connections, step-by-step, as described in the following paragraphs.

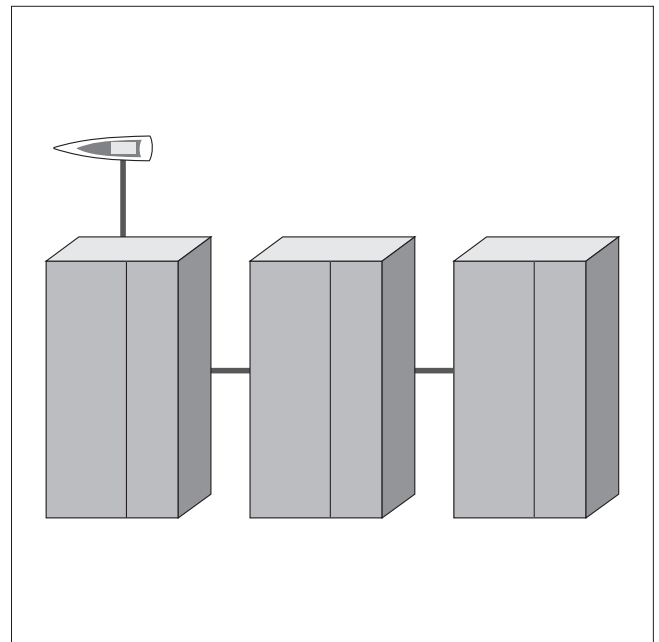
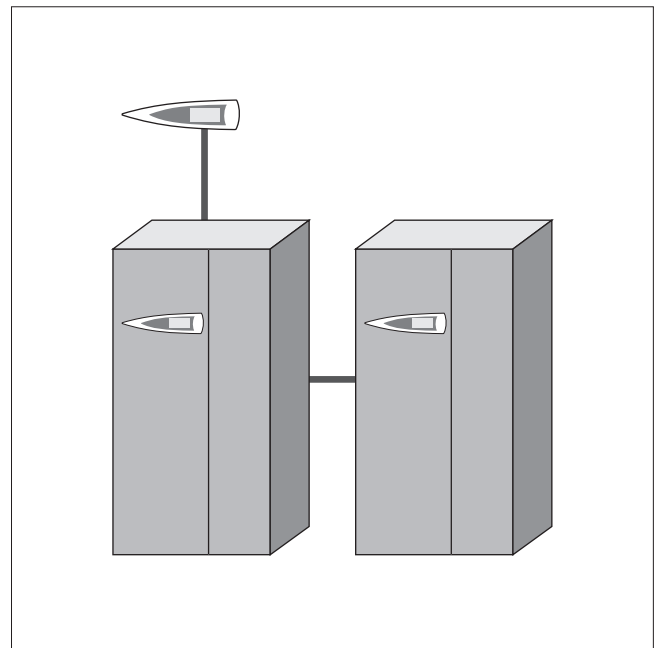

The following operations must be carried out in sequence on-site:

- 1) Connect the units together by shielded cable
- 2) Set the addresses of the units (from 0 to 10) and the user terminals (from 11 to 20)
- 3) Configure the software for the recognition and management of the units

**1) INTERCONNECTION BETWEEN THE UNITS BY SHIELDED CABLE**

In order to realize a LAN (Local Area Network) between the units, it is required that installers provide to link together all units with a dedicated cable. The cable is not supplied by CLIMAVENETA HOME SYSTEM. AWG 24 cables with two twisted pairs plus shield, such as the Belden 8723 or 8102, and AWG 24 cables with three twisted pairs plus shield, Belden 8103 or similar, are recommended. The electrical connections must be completed when the units are off and disconnected from the power supply following the below reported schema.

Connections must be provided directly on the main terminal block of the units (on the El.Panel) and not on the main board directly.

Connectors RX/TX+, RX/TX-, & GND are in different positions/Clamps based on the unit type and size: consequently please always refer to the electrical diagram inside the units where such connectors are clearly indicated.

Remember that connection between 3 connectors RX/TX+, RX/TX-, & GND has to be similar among the units: the shield has to be connected to the earth connector only in 1 unit.

Refer to the below unit for the unit interconnection. (for the right clamps refer to the el. Diagram on the unit)

**LAN CONNECTION BETWEEN 2 OR MORE UNITS**

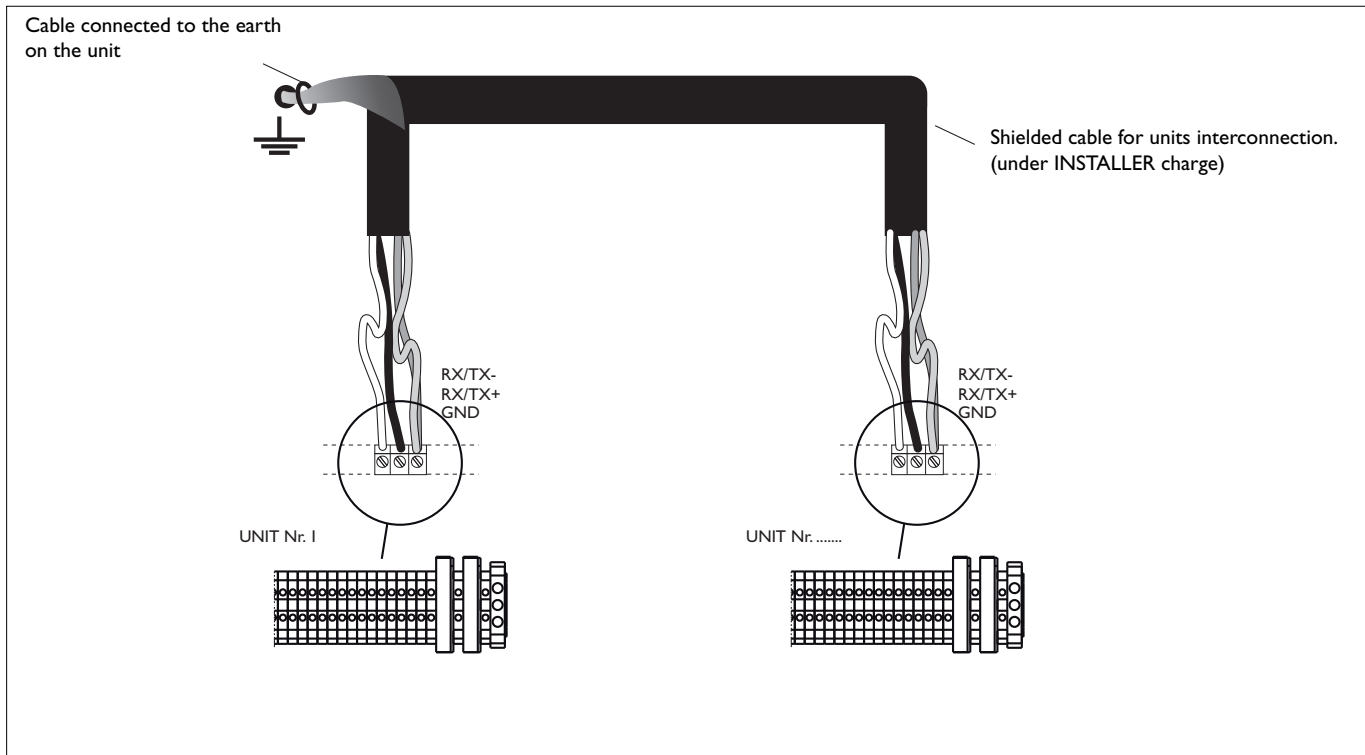

## 2) SETTING THE ADDRESSES OF THE UNITS (FROM 0 TO 10) AND THE USER TERMINALS (FROM 11 TO 20)

### CONFIGURING THE NETWORK

When it has been realized the electrical interconnection as reported on phase 1) it is required to switch to phase 2) for the address configuration for:

- A) units, addresses from 1 to 11
- B) user terminal/Display, addresses from 11 to 20

Remember that standard configuration from factory is the following:  
Address 1 for the unit  
Address 11 for the user terminal/Display

Remember that the MAX amount of units per LAN line are 10 (with max 2 in stand-by).

Right configuration and addresses for units and user terminals/Display are reported on the following resuming table.

**TABLE OF TERMINAL ADDRESSES AND LAN BOARD ADDRESSES**

LAN Board Address	Terminal address / Display
1	11
2	12
3	13
4	14
5	15
6	16
7	17
8	18
9	19
10	20

LAN Board Address	Terminal address / Display
-	32 (remote)

### A) UNITS ADDRESSES (FROM 1 TO 11)

Right units configuration is fundamental for the network in order to recognize all units connected.

Same addressing for 2 or more units in the same LAN network is not allowed: in such case the following alarm screen will appear .



Units addressing can be done only from user terminal/display.

**Units addressing can be done only if the user terminal/display is previously setted with "0" (zero) address.**

### A1) PROCEDURE TO ADDRESS THE USER TERMINAL/DISPLAY AT "0" ZERO

It is possible to set the user terminal/display address only after giving it a power supply through the telephone cable on its rear side (**connected to the main board**).

To enter configuration mode press simultaneously following buttons UP, ENTER, DOWN for 5 sec.; the following screen will appear with cursor blinking on the top -left side.



- To set the terminal address (display address setting), press the ENTER button once: the cursor will move to the address field (n°11).
- Use the UP and DOWN buttons to select the "0" (zero) value and confirm by pressing ENTER again. If the value selected is different from the one saved previously, the following screen will be displayed and the new value will be saved to the permanent memory on the display.

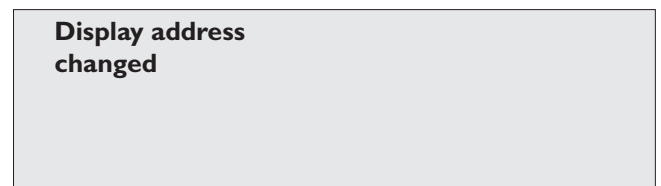

### A2) PROCEDURE TO ADDRESS THE UNITS (ADDRESSES FROM 1 TO 10)

Once the terminal address is set to "0" (zero), disconnect power supply from the board and then power it up again while at the same time holding the ALARM and UP buttons on the user terminal: wait until the following screen is displayed.



Release the buttons and set the correct address as per the table shown above, from 1 to 10. Same addressing for 2 or more units or user terminals/display in the same LAN network is not allowed.

Set the right value. Remember to set units addresses progressively from 1 to 10 within the same LAN line.

## B) USER TERMINAL/DISPLAY ADDRESSING FROM 11 TO 20

At this point unit n°1 has to be connected with user terminal/display 11, unit n°2 has to be connected with user terminal/display 12 etc.....unit n°10 has to be connected with user terminal/display 20 (look the following table)

To enter configuration mode press simultaneously following buttons UP, ENTER, DOWN for 5 sec.; the following screen will appear with cursor blinking on the top -left side.

<b>Display address setting.....:</b>	00
<b>I/O Board address:</b>	01

- To modify the terminal address (display address setting), press the ENTER button once: the cursor will move to the address field (n°00).
- Use the UP and DOWN buttons to select the right value reported on the table  
If the value selected is different from the one saved previously, the following screen will be displayed and the new value will be saved to the permanent memory on the display.

<b>Display address changed</b>
--------------------------------

## TABLE OF TERMINAL ADDRESSES AND LAN BOARD ADDRESSES

LAN Board Address	Terminal address / Display
1	11
2	12
3	13
4	14
5	15
6	16
7	17
8	18
9	19
10	20
Indirizzo unità	Indirizzo Terminale / Display
-	32 (remote/condiviso)

## 3) CONFIGURING THE SOFTWARE FOR THE RECOGNITION AND MANAGEMENT OF THE UNITS

All the settings corresponding to the LAN can be made starting from the settings menu and accessing (second line) the branch of LAN/serial setting screens. All the parameters can only be set on the MASTER unit (that is, the unit with address 1), which automatically communicates all the other units in the network of any changes.

Following reported the LI configuration screen for LAN network settings.

LAN SETTINGS	
Units Connected:	5
Mean Values Mode:	N
Stand-By Unit:	Y
Cycle Time:	h 120
Stand-By Units:	1
Stand-By Limits:	Y

- Units Connected: number of units connected in the LAN;
- Mean Values Mode: enable control based on the average readings;
- Stand-By Unit: enable the standby unit and rotation;
- Cycle Time: time between one rotation of the units and the next (in other words: time the unit remains in standby);
- Stand-By Units: number of standby units;
- Stand-By Limits: enable the function for starting the standby unit when the ambient temperature and humidity limits have been ambient temperature and humidity limits have been.

## SPECIAL FUNCTIONS OF THE LAN NETWORK

### MANAGEMENT OF AVERAGE TEMPERATURE AND HUMIDITY

When the units are connected in a LAN this network connection can be exploited to have them operate based on the average temperature and humidity of all the readings made on the active units (that is, fan operating) without alarms.

#### Calculation of the average

The average is calculated by the MASTER unit (that is, the unit with pLAN address 1) only if control based on the average values

has been enabled on the user terminal.

The MASTER unit, to perform this calculation, receives the ambient temperature and humidity values read by the probes on all the units connected in a LAN, calculates the average and then sends the resulting value to all the units.

The average temperature and humidity is only calculated on the readings from the units that:

- are not in standby (if the rotation of the standby unit is enabled);
- do not have a serious alarm (see the following paragraphs);
- have not been switched off from the user terminal.

### Enabling the use of the average reading

The use of the average temperature and humidity value for control is only enabled if:

- the function is enabled;
  - there are no problems in the LAN connection between the units.
- When problems are detected in the LAN, the unit immediately disables control based on the average values and works with the local values (that is, the values read by the probes on the unit itself).

### MANAGEMENT OF THE STANDBY UNIT

In an installation made up of units that are operating and units in standby, the operating hours of the units will not be equal, as the former will be operating for longer than the latter, which are off. To overcome this problem the pLAN network can rotate the operation of the units, thus balancing the operating hours. In practice, rotation places a unit that is on in standby and starts the unit that is in standby.

### Management of the rotation function

The rotation of the standby unit is managed entirely by the unit with address 1 (in this case, the MASTER, while all the others are SLAVES) and is performed based on times, starting from the unit with the lowest address, that is, the unit with address 1, and then progressively incrementing the address... Two standby units can be set, however only if there are at least four units connected in the LAN; in this case, the rotation of the units in standby starts with the first two (addresses 1 and 2), then the second two (2 and 3) and so on...

If the rotation time is set to zero, from that time on rotation will no longer be performed, consequently the same unit remains in standby, and is only activated in the event of faults and alarms, as described in the following paragraphs. As regards the differentials, these coincide with the values set for normal control.

## DIFFERENTIALS

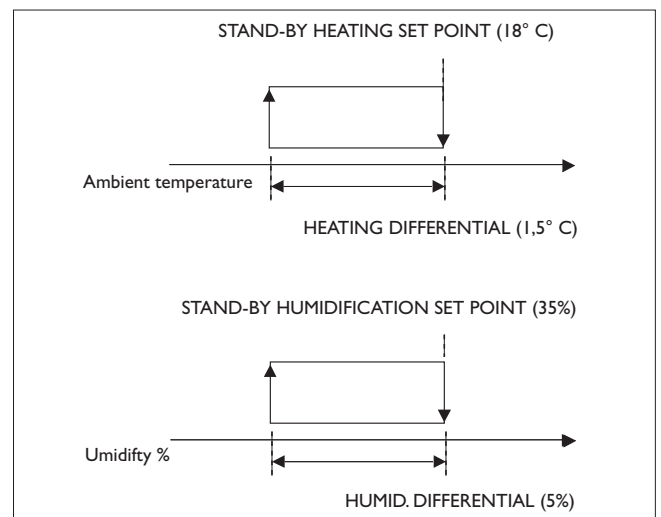
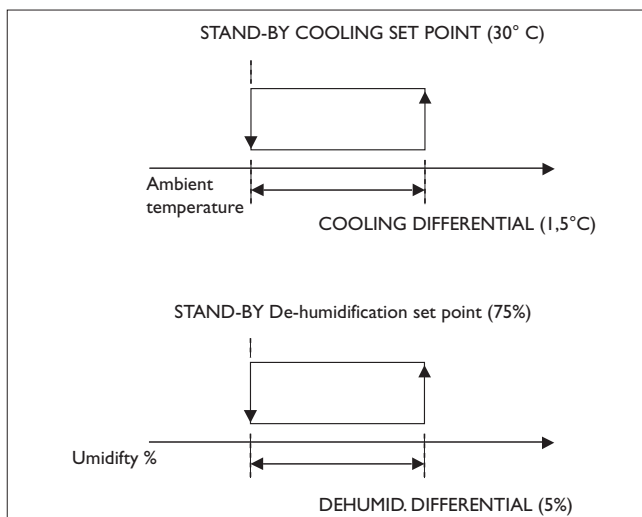

When one of the four steps shown above is activated, 30 seconds must elapse (this time cannot be modified) before the standby unit effectively starts, that is, ventilation starts.

After ventilation starts, control must be enabled (60 second delay) before the air-conditioning control devices are activated.

Temperature and humidity control is performed as for normal operation, with the only difference being the active set points, which in this case correspond to the standby unit..

The activation of the standby unit due to the limits being exceeded lasts a minimum of 10 minutes (this cannot be modified).

As regards the alarms for exceeding the temperature and humidity limits, the thresholds used by the standby unit to manage these alarms are shifted (upwards or downwards, based on the type of limit, higher or lower) by a value equal to the difference between the normal set point and the set point corresponding to the unit in standby.

There is also a procedure whereby, when the value of a set point is changed, the value corresponding to the unit in standby is automatically shifted and then updated.

### Alarm management

The network may be disconnected due to one of the following situations:

- fault with the PCO LAN board (integrated inside the PCO board: in this case, the entire board needs to be replaced);
- detachment of the connection cable from the PCO LAN board;
- power down of the unit or the PCO board;
- breakage of the cable at a point between two units

There are two possible situations:

- one or more units are no longer visible;
- the network is broken into one (or more) branches

Each unit constantly receives information on the status (that is, the visibility) of all the other units that should theoretically be connected to the network (based on the number of units in the LAN set on the user terminal). Each unit can therefore detect any disconnections. When a unit detects a disconnection in the LAN, the following occur:

- signal on the main screen;
- the unit is started if in standby;
- control based on average values disabled, if enabled;
- time count for the rotation of the standby unit suspended.

## CONNECTION TO THE REMOTE TERMINAL FROM THE BOARD

This configuration requires:

1. the use of two 'T' shunts: one fitted on the unit and one near the remote terminal;
2. the use of the 3x2 shielded cable, so that the power to the remote terminal is also supplied by the board on unit 1, connected using the 'T' shunt;

3. near the terminal, insert the ferrite to reduce any electromagnetic disturbance.

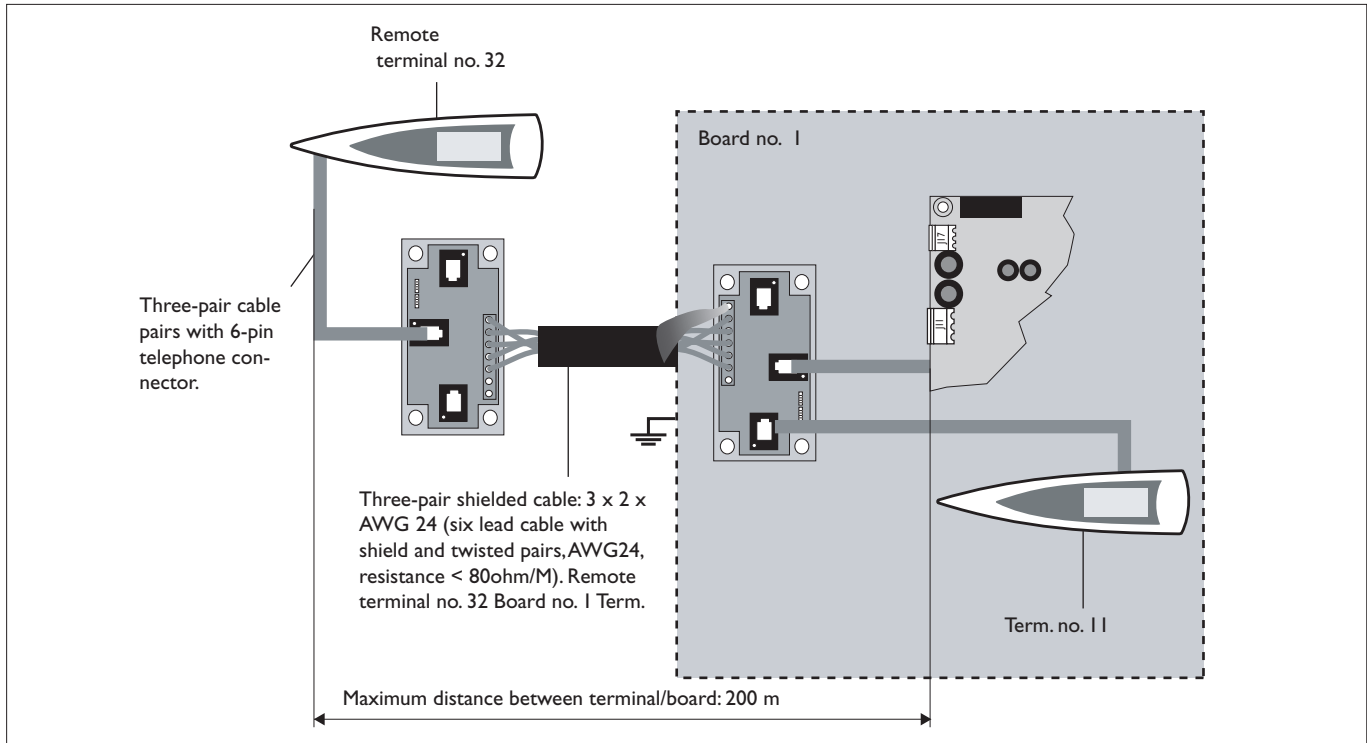

### Connections for the 2 x 2 x AWG 24 CABLE

(for connecting the remote terminal: without transferring the power supply)

terminal	function	cable connections
0	Earth	shield
1	+ VRL $\approx$ 30Vcc	
2	Gnd	First pair
3	Rx/Tx -	Second pair
4	Rx/Tx +	Second pair
5	Gnd	First pair
6	+ VRL $\approx$ 30Vcc	

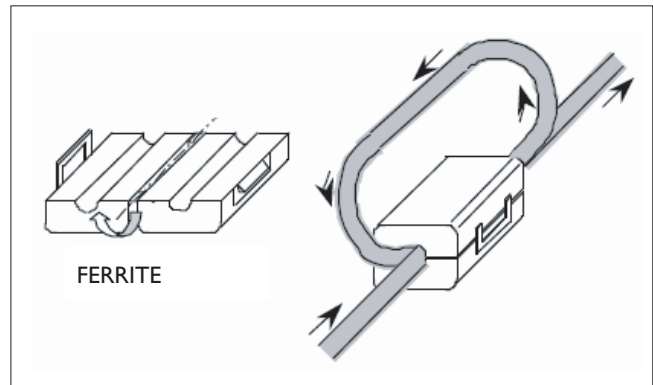

## ELECTRICAL CONNECTIONS

The electrical connections must be completed when the units are off and disconnected from the power supply. The network can have different configurations, according to the maximum distance of the connections between the boards and the remote terminal; for the connections between the remote terminal and the main board, a 'T' shunt may be required, as shown in the drawing.

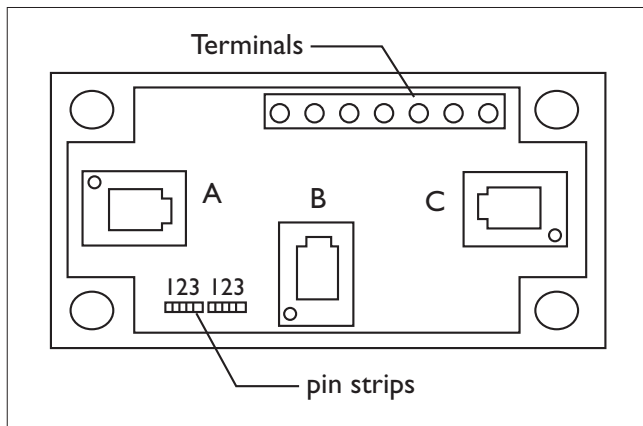

terminal	function
0	Earth (shield)
1	+VRL $\approx$ 30Vcc
2	Gnd
3	Rx/Tx-
4	Rx/Tx+
5	Gnd
6	+VRL $\approx$ 30Vcc

If both the jumpers are installed between 2 and 3 the flow of current is interrupted between the connectors separated by the dashed line.

If power is required on all the connectors, both the jumpers must be installed between 1 and 2.

Terminal 0 is an auxiliary terminal and can be used to earth the shield of the cable; the 'T' shunt must in any case be connected to a metallic part of the unit that is already earthed.

### MAXIMUM DISTANCE BETWEEN THE TERMINAL AND THE BOARD

1 For local terminals the connection to the main board is already made using a 3-pair cable and 6-pin telephone connector. The length of this cable generally does not exceed 3 metres.

2 The remote terminals can be connected to the main board using the type of telephone cable described in point 1, with a maximum distance of 50 metres.

3 For greater distances, up to a maximum of 200 metres, a shielded cable must be used (six lead cable with shield and twisted pairs, AWG24, resistance < 80 ohm/M). The cable may have 3 or 2 pairs, depending on whether the power needs to be supplied to the terminals. The cable is not supplied by CLIMA-VENETA HOME SYSTEM s.r.l.

AWG 24 cables with two twisted pairs plus shield, such as the Belden 8723 or 8102, and AWG 24 cables with three twisted pairs plus shield, Belden 8103 or similar, are recommended.

## DISPLAYING THE NETWORK FROM THE TERMINAL

From any terminal in the network, holding the UP + ENTER + DOWN buttons for at least 10 seconds, will display the << NetSTAT >> screen ( see Fig. 2).

The NetSTAT screen shows all the LAN boards and all the terminals connected in the network, including the shared remote terminal, with the corresponding addresses.

In the example, the network is made up of 3 LAN boards with addresses 1, 2, 3, and 4 user terminals with addresses 11, 12, 13 and 32.

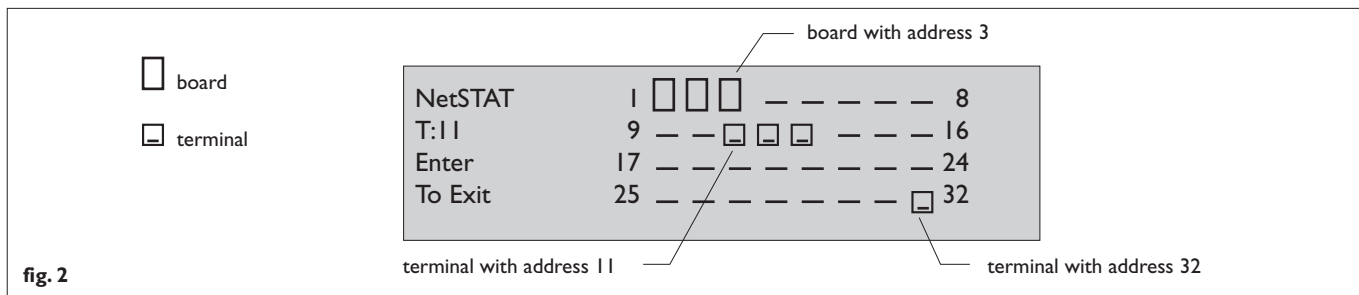

fig. 2

NB: this part is not intended to go into detail on the various versions and options available in the CLIMAVENETA range as regards supervisory systems, a topic that will be dealt with in a special manual. Rather, the purpose is to provide a rapid indication of the operations to be performed on the unit software by setting parameters from the user terminal so as to activate the database on the controller.

Therefore below is a short list of the operations to be carried out for the management of a serial interface board, in particular:

- 1) Options and serial boards currently available
- 2) Installation
- 3) Configuration of the software from the terminal
- 4) Configuration / Physical development of the serial network

**1) Options and serial boards currently available**  
 Currently CLIMAVENETA offers the market a series of serial interfaces that allow the ACCURATE precision air-conditioners to share their control variables with local or remote BMS (Building Management Systems), both proprietary systems and those more commonly found on the market today.

The interfacing and sharing of the control variables with such systems can be performed using serial boards/interfaces that are compatible with the BMS that the variables should be exchanged with.

Consequently, the various OPTIONS that can be ordered when purchasing the unit (and can also be supplied subsequently) include the following serial interface boards:

- **CLOCK** board used for identifying alarm events by time. The clock board **MUST NOT** be installed in the same SLOT as the serial boards listed below
- **RS485** for dialogue with protocols: CAREL and MODBUS
- **RS232** for dialogue with protocol RS232
- **BACNET** for dialogue with protocol: BACNET
- **ETHERNET** for dialogue with protocols: SNMP and TCP/IP-
- **LON** for dialogue with protocol: LON

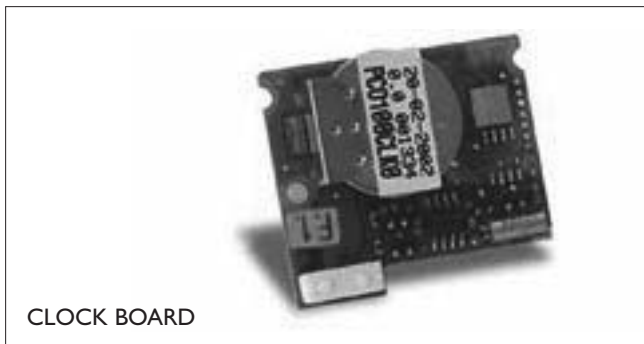

CLOCK BOARD

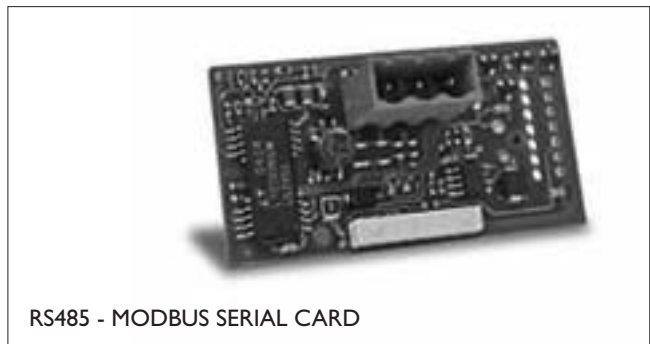

RS485 - MODBUS SERIAL CARD

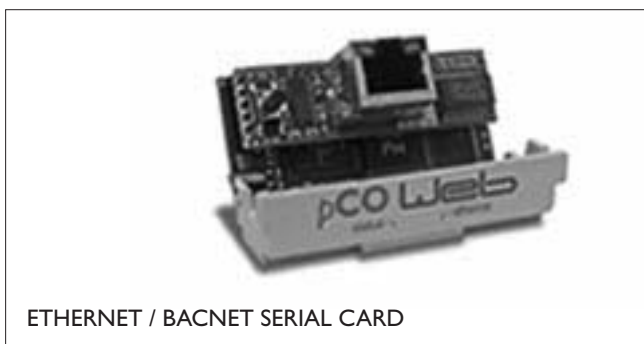

ETHERNET / BACNET SERIAL CARD

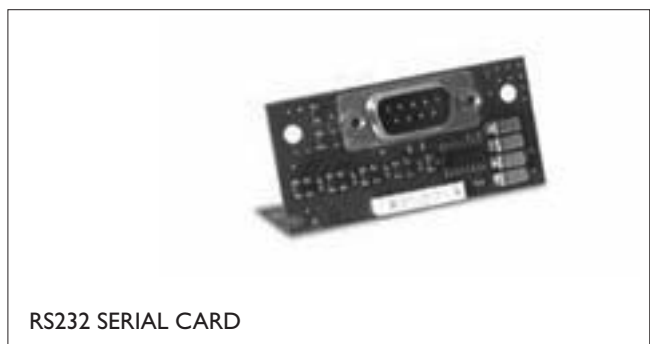

RS232 SERIAL CARD

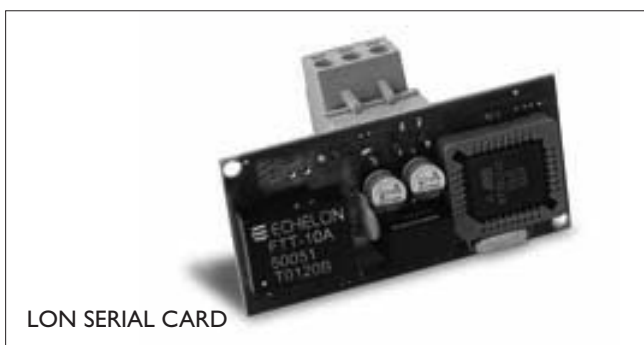

LON SERIAL CARD

## 2) Installation

These serial interface boards must be fitted onto the pCOI motherboard, in the special slot shown here.

### Mounting

To install the card in the pCO unit respect the following instructions (Fig. 1...4):

1. remove the "serial card" placement cover with a screwdriver (Fig. 1);
2. removing the pre-punctured plastic you get the hole which corresponds to the tree-pole terminal out (Fig. 2);
3. insert the optional card into the corresponding connector; taking care that the card is firmly placed on both plastic supports on the pCO case (Fig. 3);
4. close the cover using the screwdriver making the outside card terminal fits with the punched hole made on the cover (Fig. 4).

The connection with the RS485 network is carried out by means of the plug-in terminal connector on the card. Pin-wiring of the connector is stamped on the card (see table 1). If the card is placed in the last position of the supervision serial line, pins 2 and 3, you must connect a 120 - - 1/4 W end line resistor, as shown in Fig. 6.

Obviously it cannot be placed more that 1 serial card at same time inside the PCOI motherboard. Consequently unit can communicate just whit 1 BMS system at same time

### Warning. When handling the card, please follow the advice below

Electrical damage may occur to the electronic components as a result of electrostatic discharges from the operator. Suitable precautions must be therefore be taken when handling these components:

- before using any electronic component or card, ground yourself (not touching the card does not prevent a spike, as static electricity can produce a 10000V spike discharge which can form an arc of about 1cm);
- all components must be kept inside their original package as long as possible. If necessary, take the board from its package and place it into an antistatic package without touching the back of the board with your hands;
- absolutely avoid non-antistatic plastic bags, polystyrene or spongee;
- do not pass the card directly to other operators (to prevent from electrostatic induction and discharges).

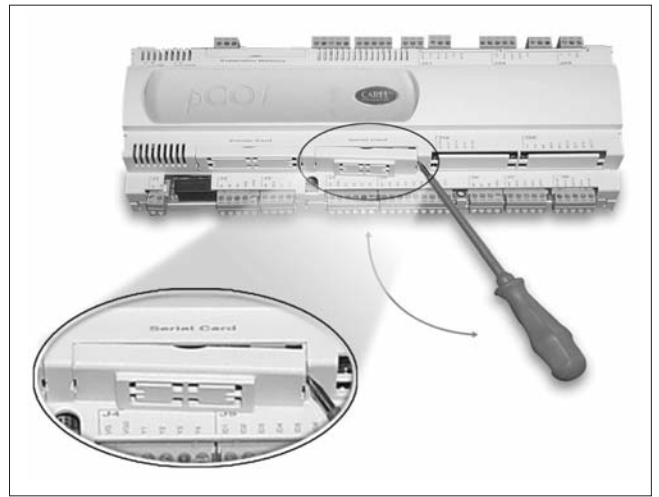

fig. 1

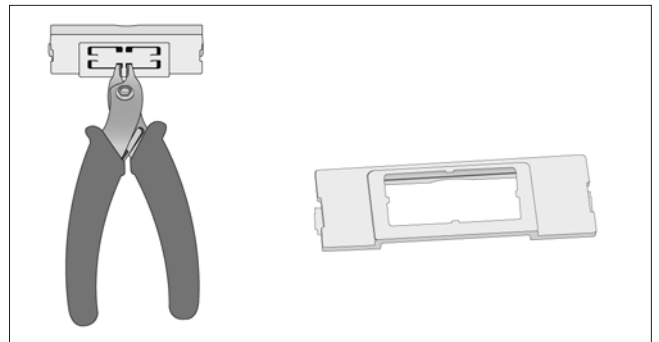

fig. 2



fig. 3



fig. 4

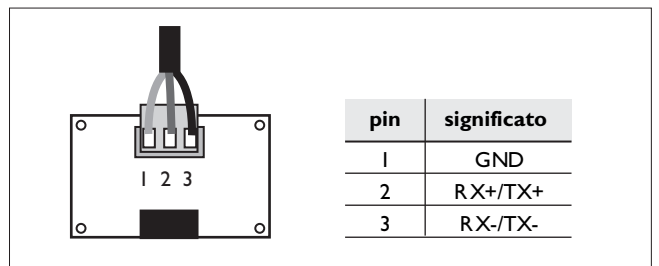

fig. 5

### 3) Configuration of the software from the terminal

Once the board has been installed, it must be set with the address and configured as described below.

This operation then needs to be repeated for each individual unit where the serial board has been installed.

Access screen **L3** on the user terminal: the following parameters need to be set.

- Unit Id: serial address of the unit (this address has nothing to do with the LAN address).  
The address will be sent through serial link as the unit identifier; therefore the serial network cannot have more than one unit with the same address.
- Baud-rate: (bits per second): the value set must be congruent with the type of serial link used. For further information contact the proprietor of the system.
- Protocol: selectable (only with RS485 board installed) between CAREL (standard set) and MODBUS
- Serial ON/OFF: selected to enable or disable serial communication.

### 4) Configuration/physical development of the serial network

The configuration and subsequent development of the network strictly depends on the type of BMS being interfaced with. As a result, contact the proprietor of the supervisory system directly. Climaveneta personnel will not develop serial networks on their own initiative and cannot be held liable for the incorrect development of such not for any damage that may derive.

SERIAL SETUP	
Unit Id:	001
Baud-Rate:	1200
Protocol:	Standard
Serial ON/OFF:	Y

<b>PROBLEM</b>	<b>CAUSE</b>	<b>SOLUTION</b>
<b>The user terminal does not switch on or does not communicate with the unit.</b>	<p>The connection cable between the pCOI board and the user terminal may be detached or broken. Possible power failure to the pCOI board. Possible blown fuse on the pCOI board or in the power supply line.</p>	<p>Check the connection between the user terminal and the pCOI board. Check that the pCOI board is powered and on, check any fuses in the power supply line.</p>
<b>The user terminal is on but no icons or menu items are displayed.</b>	<p>The address of the pCOI board or the user terminal may be incorrect. The contrast of the display may have been adjusted by mistake</p>	<p>Check that the LAN address of the pCOI board and the address of the user terminal are compatible. Check by pressing the PGR+ALARM+UP buttons to increase or PGR+ALARM+DOWN to decrease the contrast.</p>
<b>The shared user terminal cannot communicate with the unit or the units connected in the network (LAN).</b>	<p>The address of the terminal may be incorrect. The connection cable between the units may be detached or broken. The connection cable may be detached or broken.</p>	<p>Check the LAN connection between the units. Check the connection on the three-way 'T' shunt.</p>

If after having checked all the possible causes of the problems described here the problem has not been resolved, contact your nearest service centre for further information on how to proceed and resolve the problem.



**Via Duca D'Aosta 107**  
**31030 Mignagola (TV) - ITALY**  
**tel. +39 0422 4131**  
**fax +39 0422 413659**